

REVISION HISTORY			
REV	DESCRIPTION	DATE	APPROVED
1	-	-	-
2	-	-	-
3	-	-	-

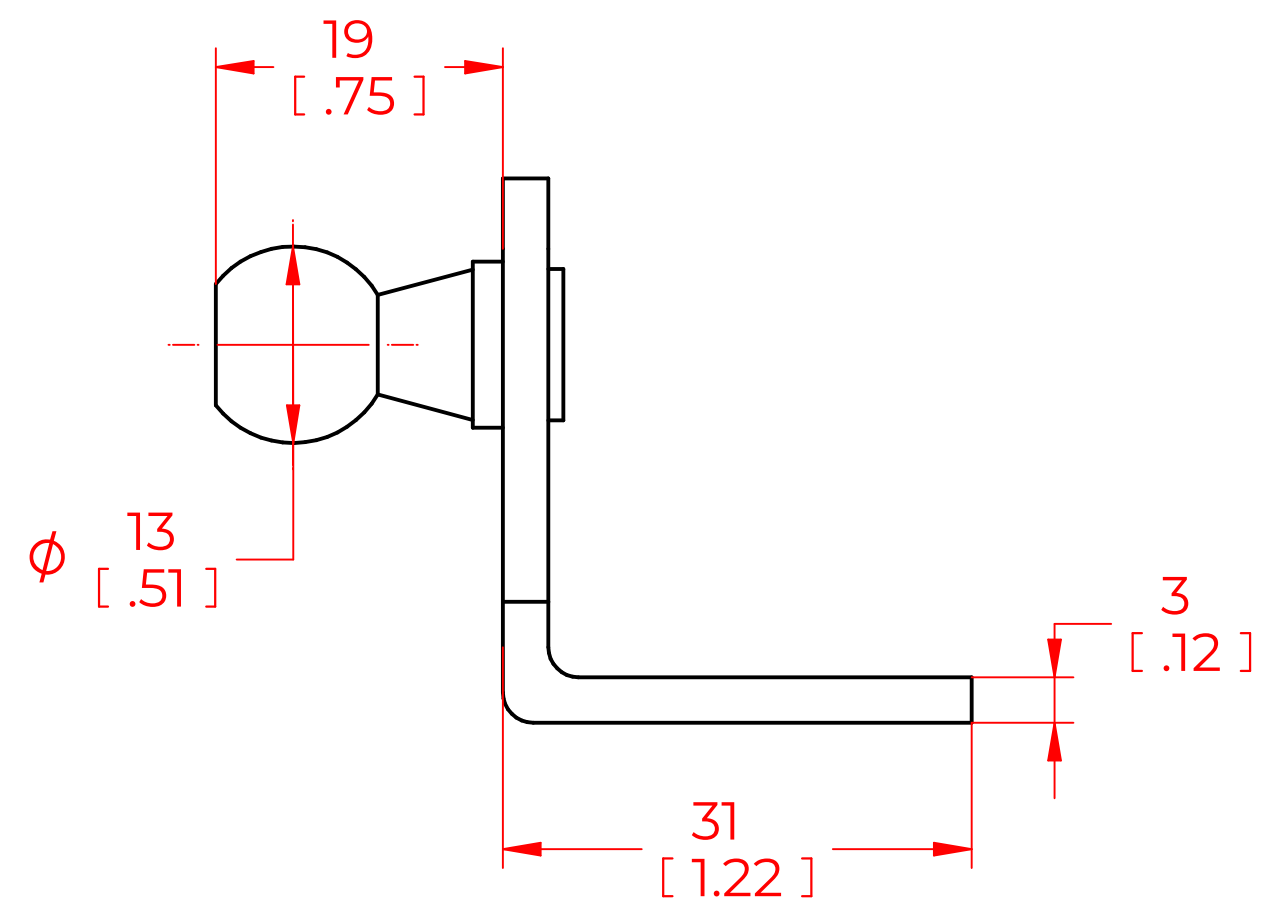
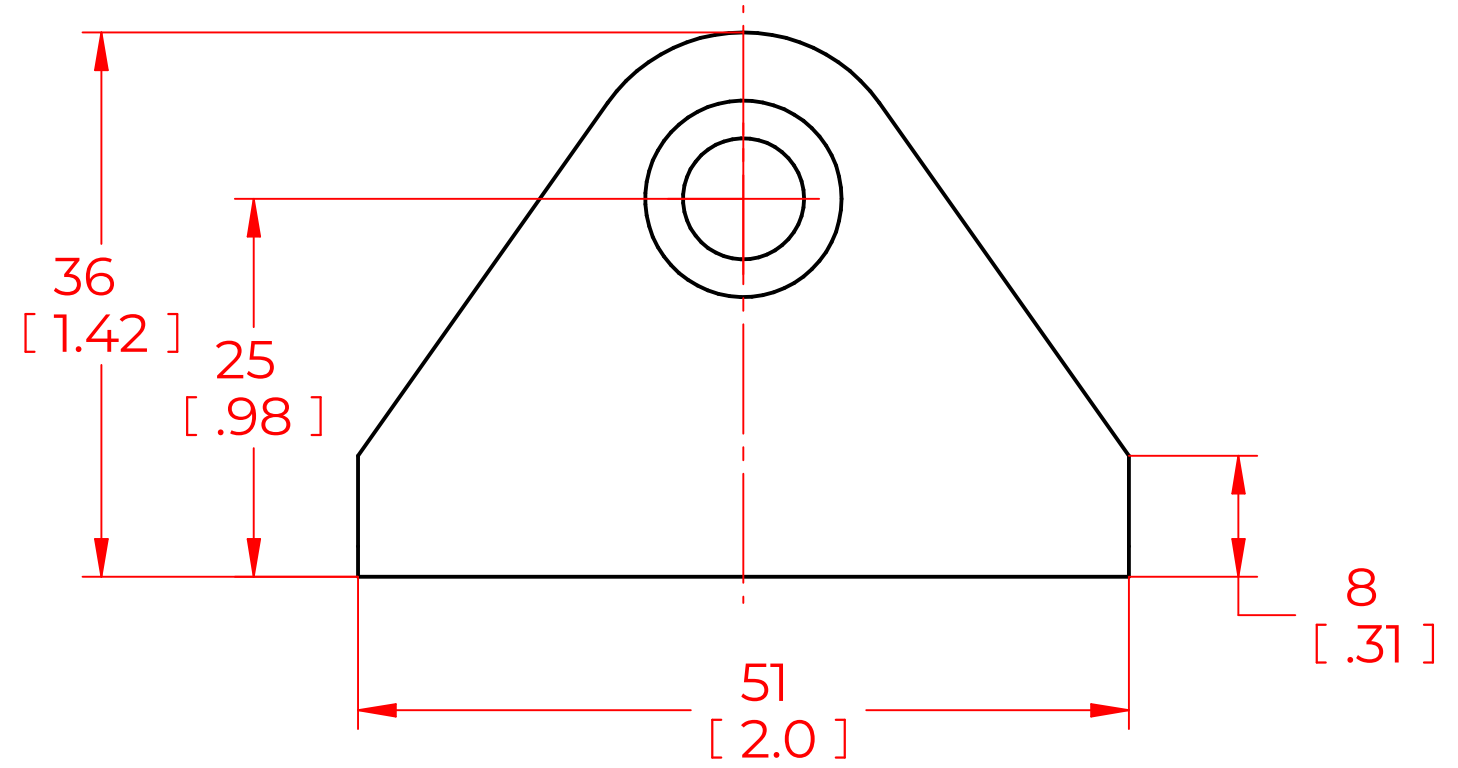
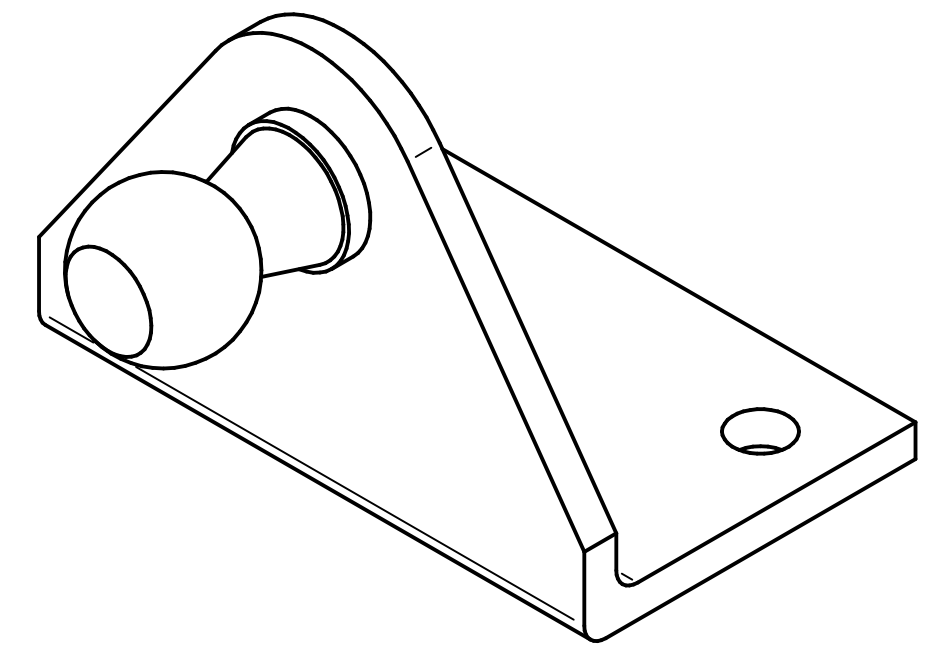
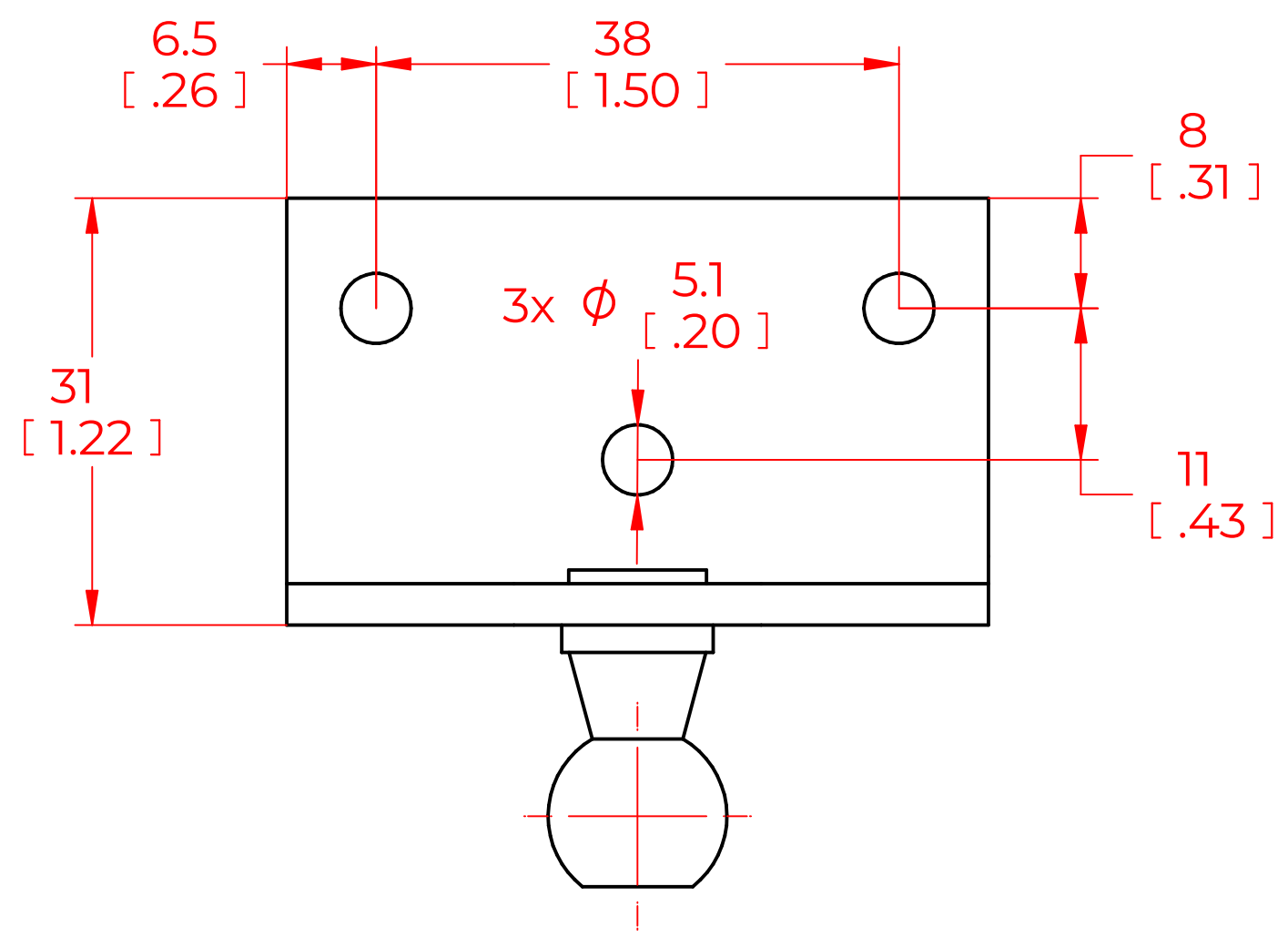

- NOTES:**
- 1) MATERIAL: ZINC PLATED STEEL
 - 2) BALL STUD DIAMETER: 0.51 IN / 13 MM
 - 3) DESCRIPTION: 90 DEG BRACKET FOR < 90 LBS

NORMONT	NAME	DATE	
	DRAWN	CSH	04/05/2023
THIS DOCUMENT AND ITS CONTENTS ARE THE PROPERTY OF NORMONT THIS DOCUMENT CONTAINS CONFIDENTIAL PROPRIETARY INFORMATION. THE REPRODUCTION, DISTRIBUTION, UTILISATION OR THE COMMUNICATION OF THIS DOCUMENT OR ANY PART THEREOF, WITHOUT EXPRESS AUTHORISATION IS STRICTLY FORBIDDEN.	CHECKED	-	
	PART No.	NBR02-02	
	TITLE	BRACKET	
	TOLERANCES	THIRD ANGLE PROJECTION	
REMOVE ALL BURRS AND BREAK ALL SHARP EDGES	X.X	± 0.060	SCALE 2:1
	X.XX	± 0.030	
	X.XXX	± 0.010	SIZE C
	ANGLES	± 1°	
ALL DIMENSIONS ARE DUAL UNLESS OTHERWISE SPECIFIED	HOLES	± 0.005	SHEET 1 OF 1