

REVISION HISTORY			
REV	DESCRIPTION	DATE	APPROVED
1	-	-	-
2	-	-	-
3	-	-	-

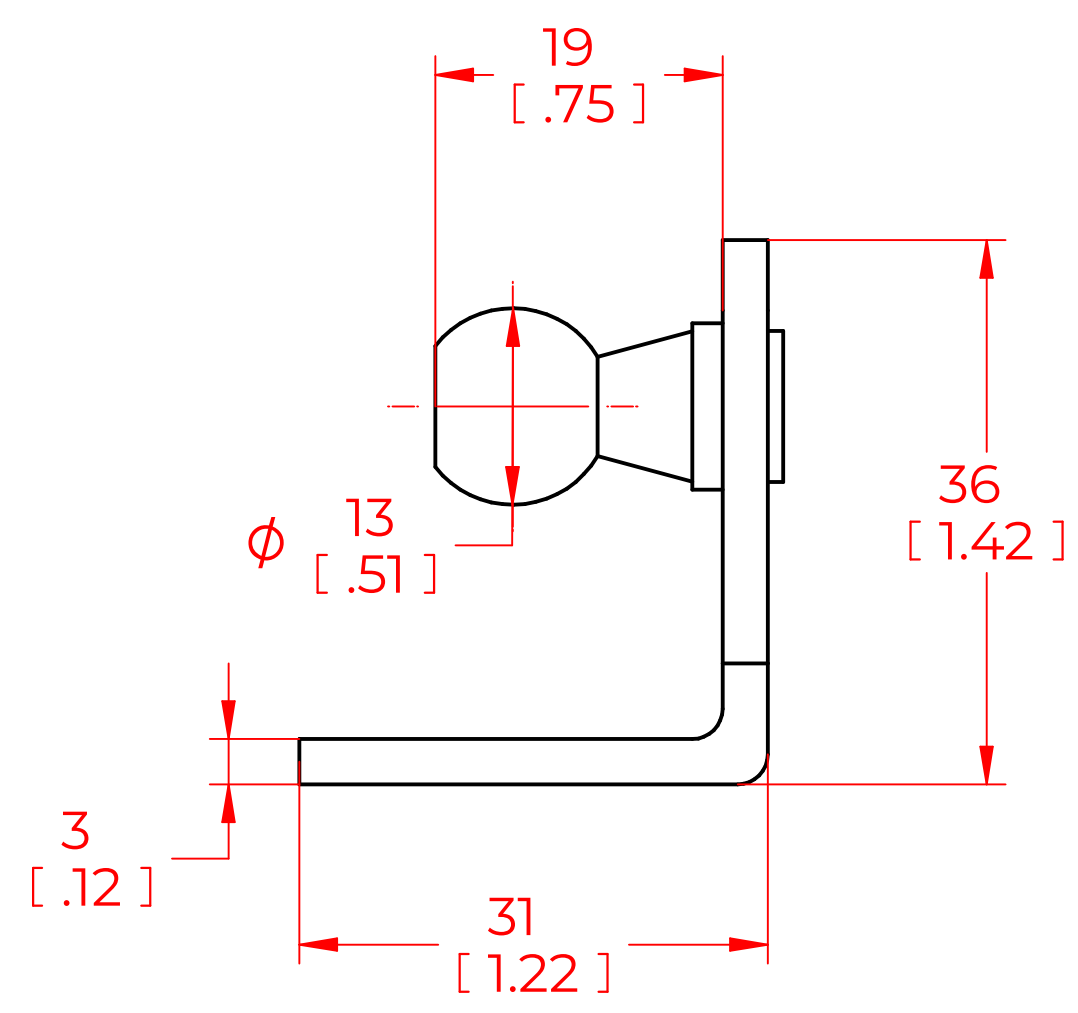
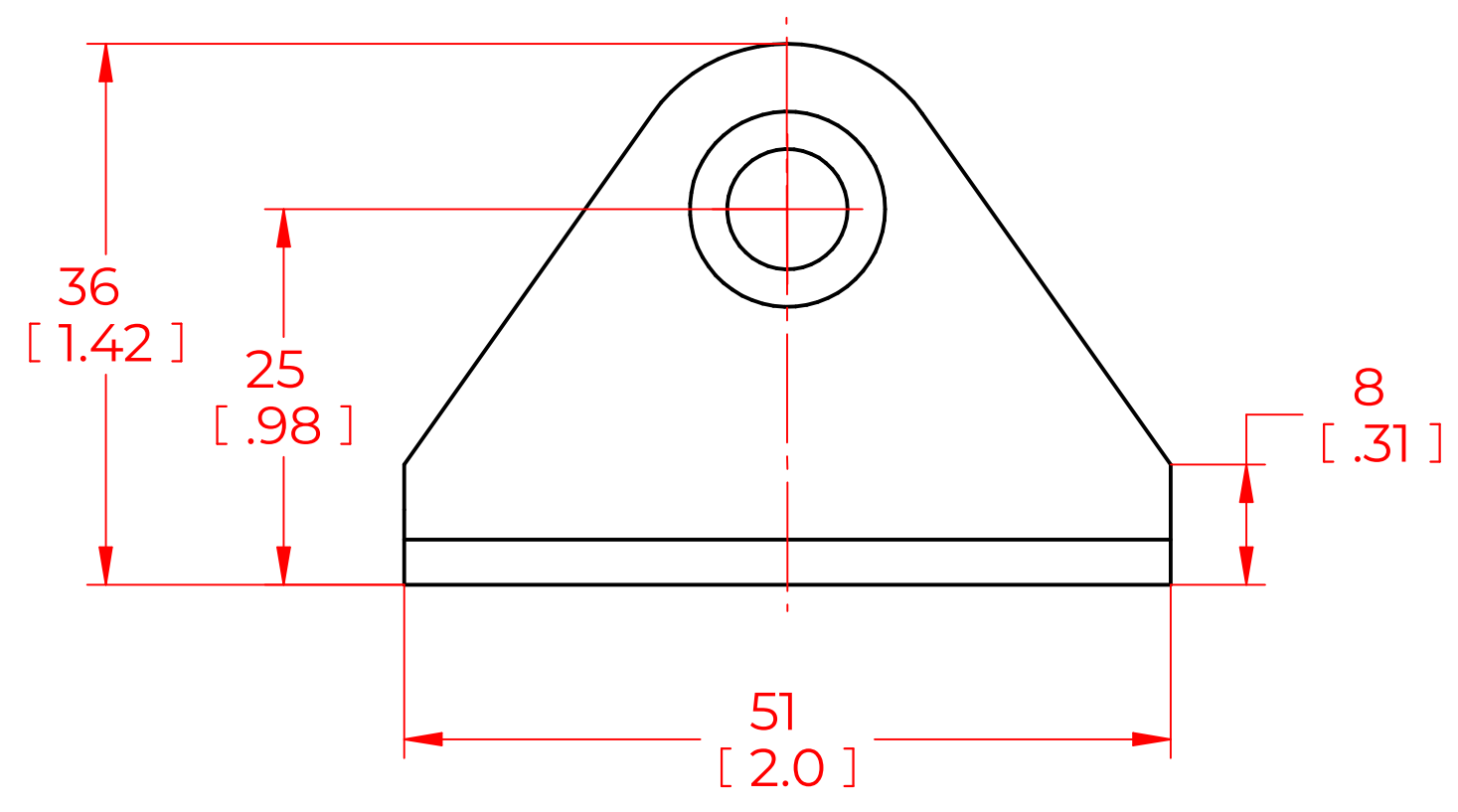
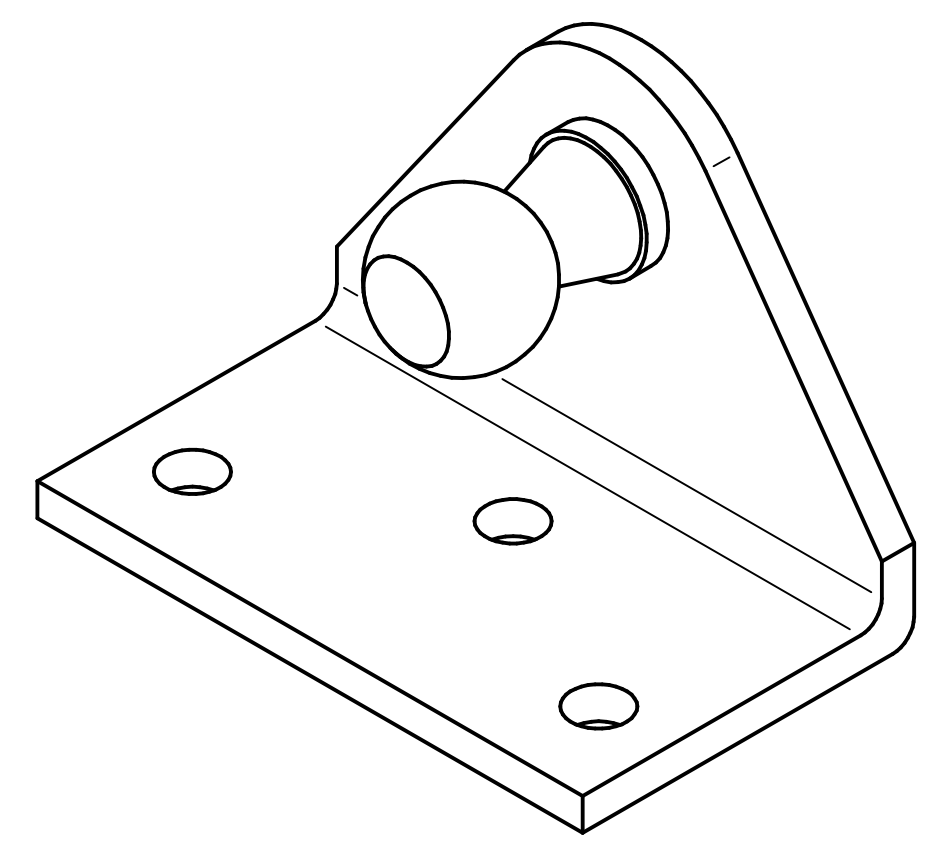
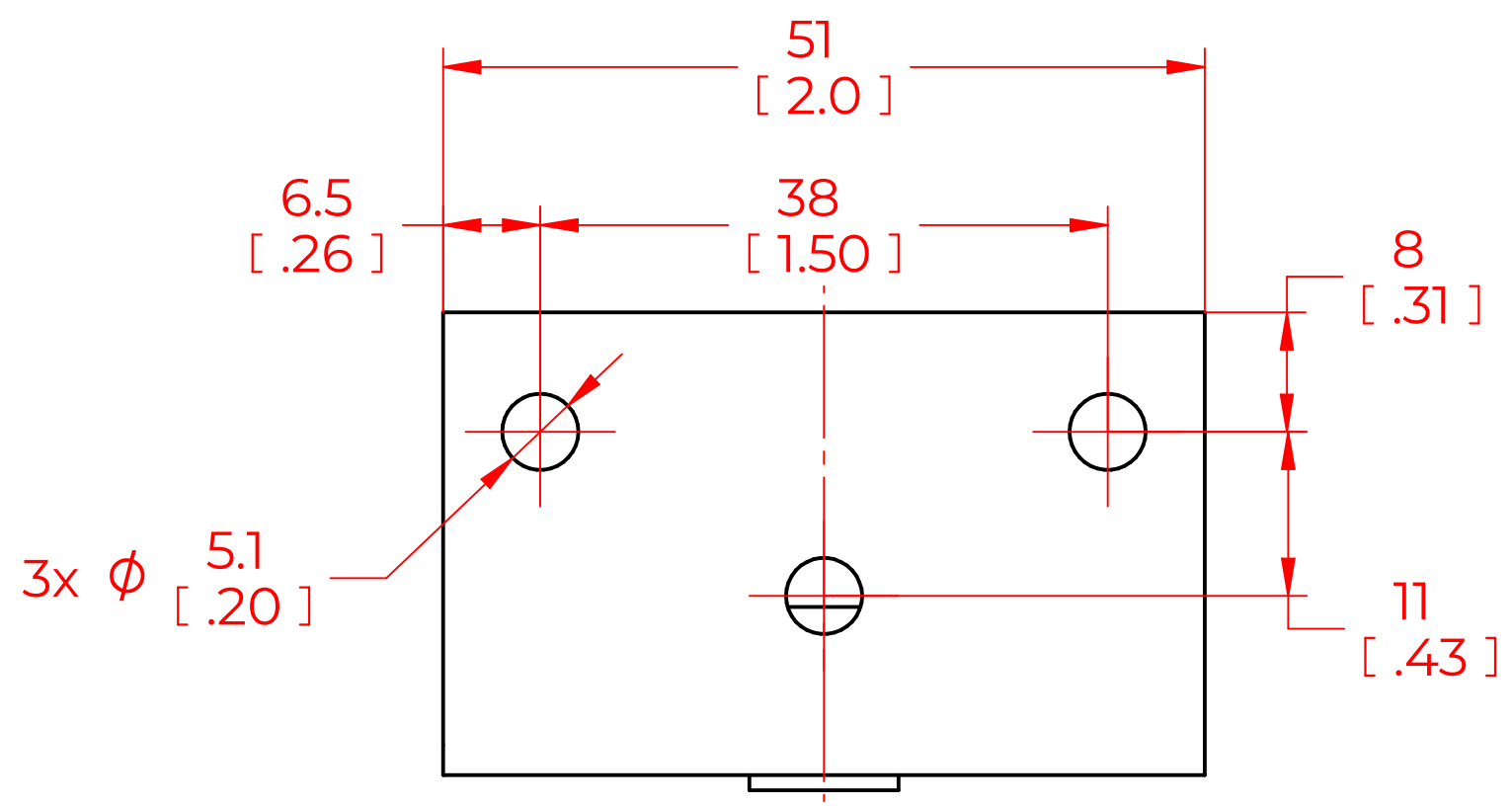

- NOTES:**
- 1) MATERIAL: ZINC PLATED STEEL
  - 2) BALL STUD DIAMETER: 0.51 IN / 13 MM
  - 3) DESCRIPTION: REVERSE 90 DEG / BRACKET FOR < 90 LBS

<b>NORMONT</b>	NAME	CSH	DATE	04/05/2023
	DRAWN			
THIS DOCUMENT AND ITS CONTENTS ARE THE PROPERTY OF NORMONT THIS DOCUMENT CONTAINS CONFIDENTIAL PROPRIETARY INFORMATION. THE REPRODUCTION, DISTRIBUTION, UTILISATION OR THE COMMUNICATION OF THIS DOCUMENT OR ANY PART THEREOF, WITHOUT EXPRESS AUTHORISATION IS STRICTLY FORBIDDEN.	CHECKED	-		
	PART No.	NBR02-02R		REV
	TITLE	BRACKET		
	TOLERANCES	X.X	± 0.060	THIRD ANGLE PROJECTION
	X.XX	± 0.030	2:1	
	X.XXX	± 0.010	SIZE	
REMOVE ALL BURRS AND BREAK ALL SHARP EDGES	ALL DIMENSIONS ARE <b>DUAL</b> UNLESS OTHERWISE SPECIFIED	ANGLES	± 1°	SHEET 1 OF 1
		HOLES	± 0.005	