

REVISION HISTORY			
REV	DESCRIPTION	DATE	APPROVED
1			
2			
3			

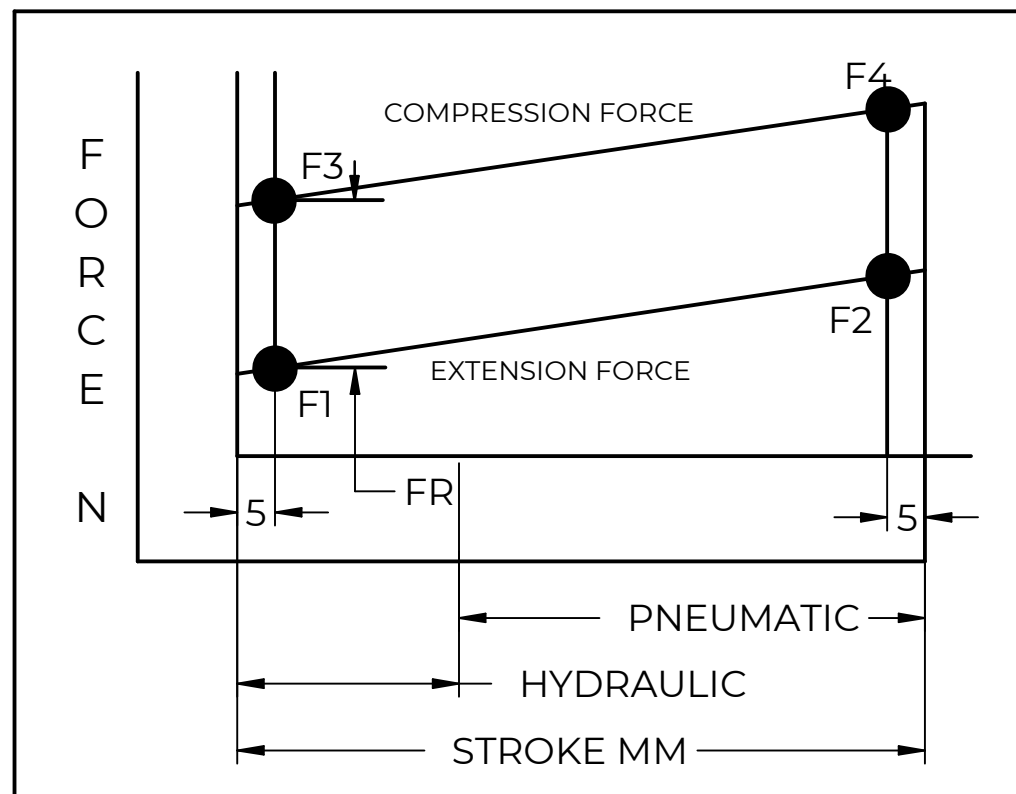
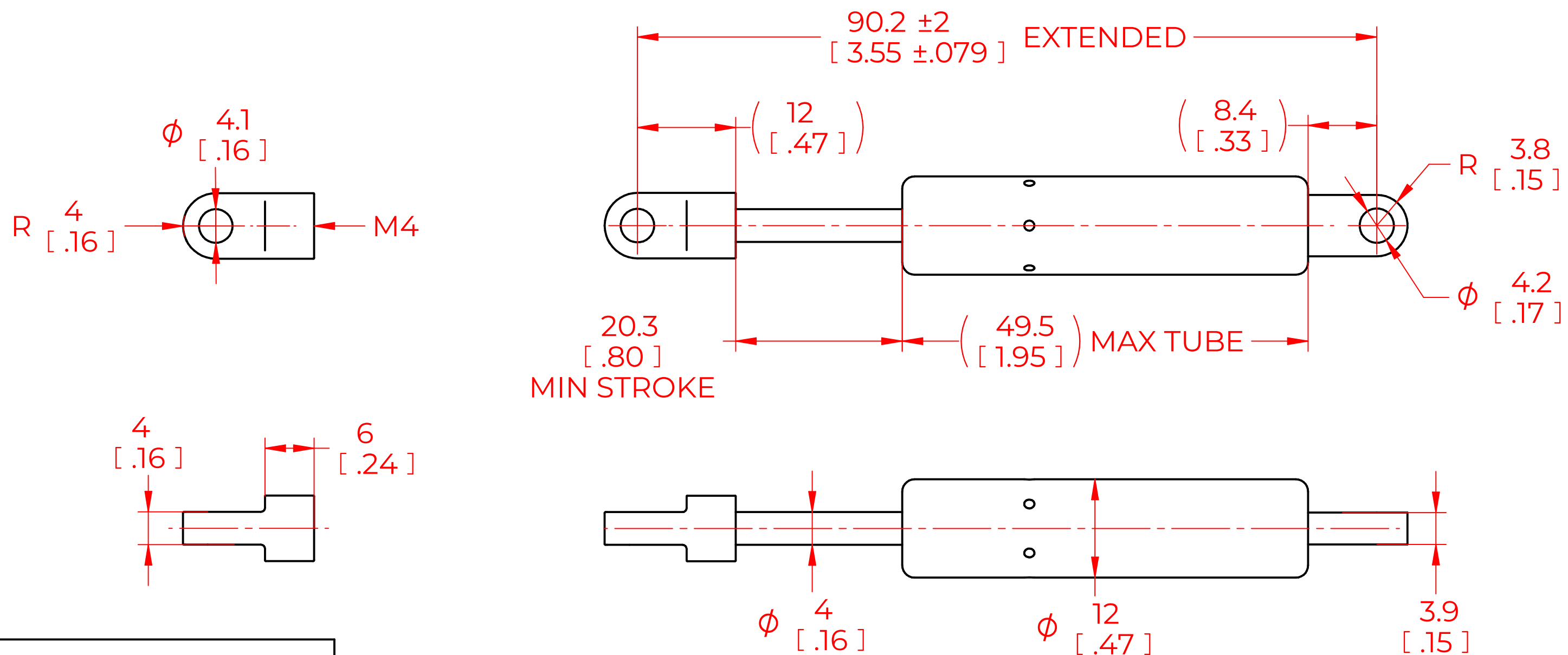

FORCES (STATICALLY MEASURED)	
F1	(F2)
25 LBS (111 N) +10% -5%	

NOTES:

- 1) MATERIAL: CYLINDER - HEAVY GAUGE STEEL, BLACK PAINT. ROD - HARDENED STEEL BLACK NITRIDE.
- 2) DIMENSIONS ASSUMING END CONNECTORS ARE FULLY SCREWED INTO PLACE.
- 3) DRAWING LENGTHS (NOT DIMENSIONED) OF CYLINDER AND ROD BODIES ARE NOT TO SCALE.
- 4) OPERATING TEMPERATURE: -30°C TO +80°C.
- 5) STANDARD LABEL TO INCLUDE PART NUMBER, DATE CODE AND WARNING MESSAGE. LABEL NOT TO BE REMOVED.
- 6) GAS SPRING NOT TO BE CHANGED OR MODIFIED FROM ITS ORIGINAL MANUFACTURED INTENT.
- 7) GAS SPRING IS SUGGESTED TO BE MOUNTED SHAFT DOWN (ROD DOWN) FOR MAXIMUM PERFORMANCE.
- 8) CONNECTORS TO BE ORIENTED AS SHOWN ±5°.
- 9) GAS SPRINGS WILL BE SEALED IN CLEAR PLASTIC BAGS TO AVOID DAMAGE, DUST, OR OTHER FOREIGN OBJECTS.
- 10) GAS SPRING TO BE ASSEMBLED WITH END FITINGS COMPLETELY FASTENED.
- 11) GAS SPRINGS ARE NOT TO BE OPENED.

NORMONT	DRAWN	NAME	DATE	
	CHECKED	CSH	06/29/2023	
	PART No. NSM355A25E		REV	
THIS DOCUMENT AND ITS CONTENTS ARE THE PROPERTY OF NORMONT THIS DOCUMENT CONTAINS CONFIDENTIAL PROPRIETARY INFORMATION. THE REPRODUCTION, DISTRIBUTION, UTILISATION OR THE COMMUNICATION OF THIS DOCUMENT OR ANY PART THEREOF, WITHOUT EXPRESS AUTHORISATION IS STRICTLY FORBIDDEN.	TITLE		SCALE	
	GAS SPRING		2:1	
	TOLERANCES		THIRD ANGLE PROJECTION	SIZE
	X.X	± 0.060		
	X.XX	± 0.030		C
X.XXX	± 0.010			
ANGLES	± 1°			
REMOVE ALL BURRS AND BREAK ALL SHARP EDGES	ALL DIMENSIONS ARE DUAL UNLESS OTHERWISE SPECIFIED	HOLES	± 0.005	
		SHEET 1 OF 1		