

REVISION HISTORY			
REV	DESCRIPTION	DATE	APPROVED

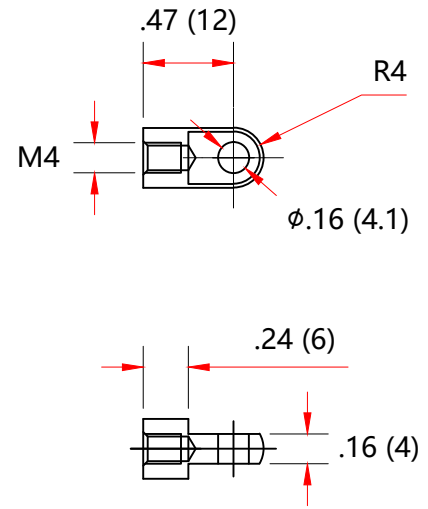
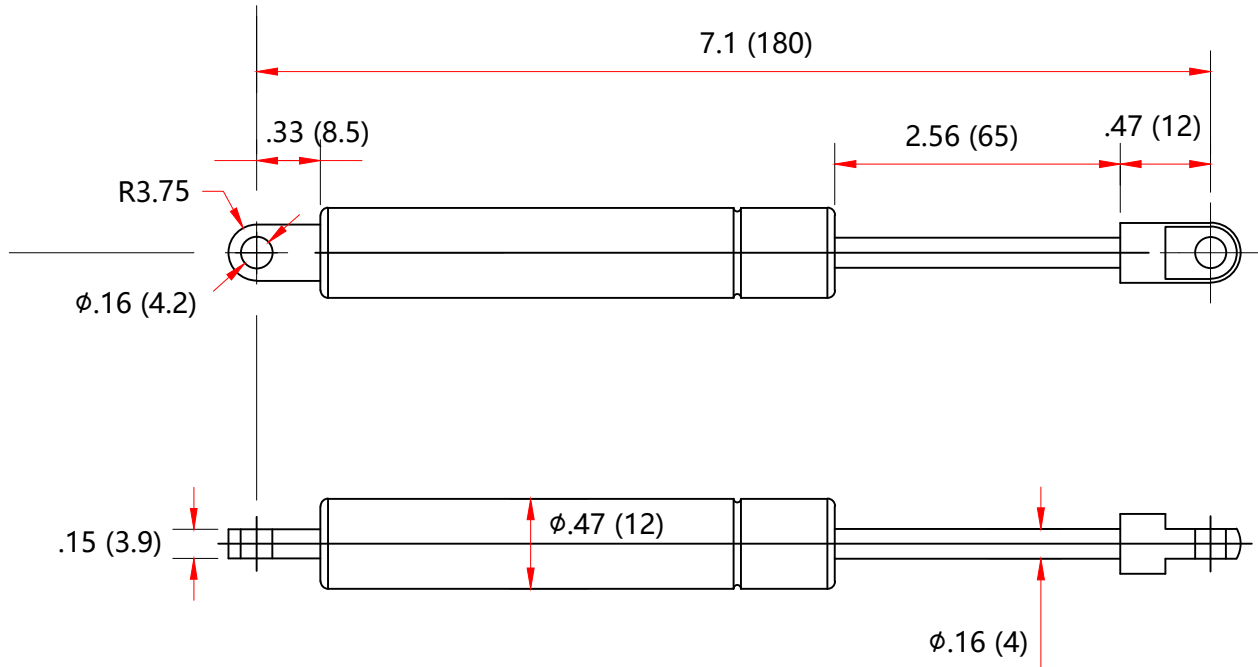

- NOTES**
- 1 . MATERIAL : CYLINDER - HEAVY GAUGE STEEL, BLACK PAINTING, ROD - HARDENED STEEL BLACK NITRIDE
  - 2 . FORCE: 5LBS/ 22N
  - 3 . Dimensions assuming end connectors are fully screwed into place
  - 4 . Drawing lengths (not dimensioned) of cylinder and rod bodies are not to scale
  - 5 . Label to include part number, date code, and warning message. Label not to be remove
  - 6 . Label to include part number, date code, and warning message. Label not to be remove
  - 7 . Gas Spring not to be modified, or changed from manufactured, original, product
  - 8 . Gas Spring is suggested to be mounted shaft down (rod down) for maximum performance
  - 9 . Connectors to be lined up per drawing. 5 degree division permitted
  - 10 . Gas Springs will be individually packed in sealed clear plastic bags, to avoid damage, dust, or other foreign material - objects
  - 11 . Gas Spring to be assembled per the drawing with end fittings assembled / fastened
  - 12 . Gas Springs are not to be opened
  - 13 . Inside of each end fitting to be greased

<b>NORMONT</b>	DRAWN	NAME	DATE
	CHECKED	Faith	1/20/23
	DWG NO	NSM710A5E	REV 0
	TITLE <b>Gas Spring</b>		
REMOVE ALL BURRS & BREAK ALL SHARP EDGES	ALL DIMENSIONS ARE IN <b>inch</b> UNLESS OTHERWISE SPECIFIED		TOLERANCES X.X $\pm 0.060$ X.XX $\pm 0.030$ X.XXX $\pm 0.015$ ANGLES $\pm .015^\circ$ HOLES $\pm 0.005$
	THIRD ANGLE PROJECTION		SCALE N.T.S.
			SIZE <b>B</b>
	SHEET 1 OF 1		