

REVISION HISTORY			
REV	DESCRIPTION	DATE	APPROVED

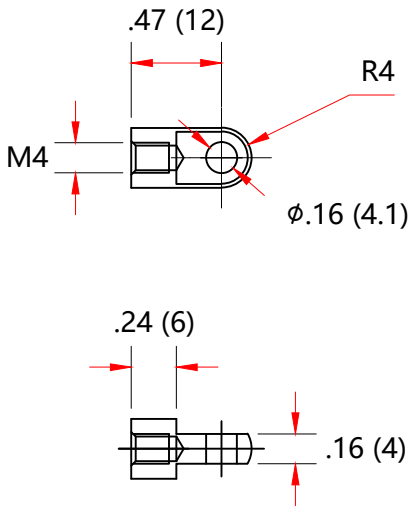
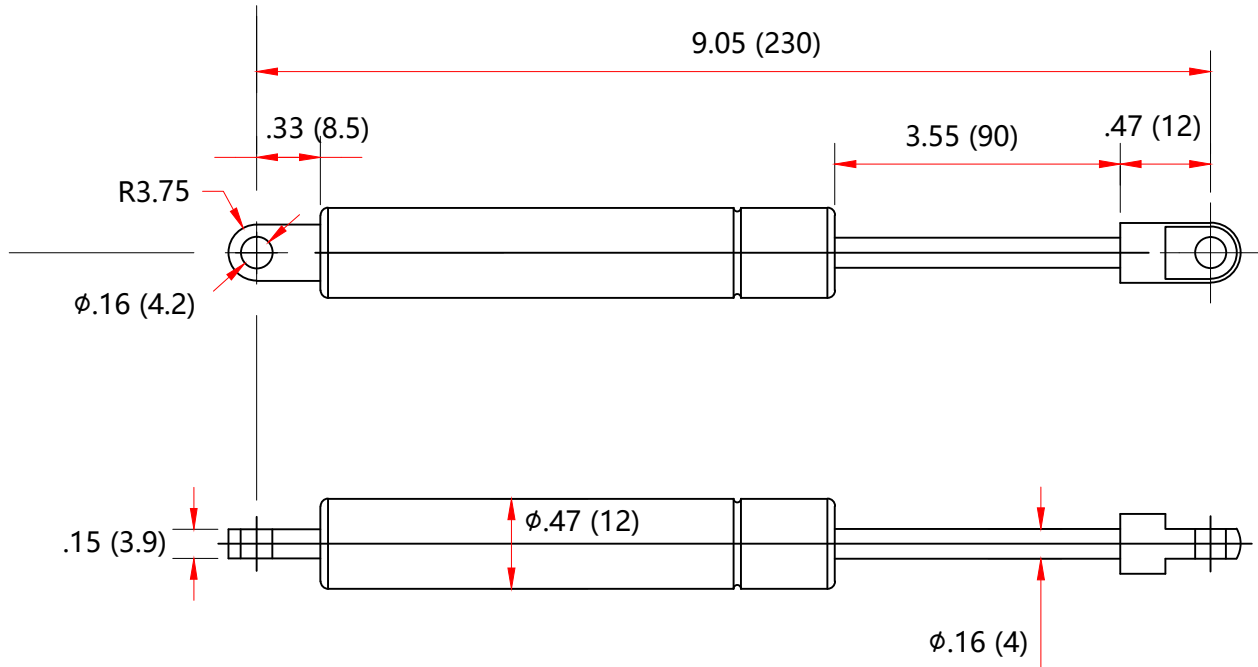

- NOTES
- 1 . MATERIAL : CYLINDER - HEAVY GAUGE STEEL, BLACK PAINTING, ROD - HARDENED STEEL BLACK NITRIDE
 - 2 . FORCE: 5LBS/ 22N
 - 3 . Dimensions assuming end connectors are fully screwed into place
 - 4 . Drawing lengths (not dimensioned) of cylinder and rod bodies are not to scale
 - 5 . Label to include part number, date code, and warning message. Label not to be remove
 - 6 . Label to include part number, date code, and warning message. Label not to be remove
 - 7 . Gas Spring not to be modified, or changed from manufactured, original, product
 - 8 . Gas Spring is suggested to be mounted shaft down (rod down) for maximum performance
 - 9 . Connectors to be lined up per drawing. 5 degree division permitted
 - 10 . Gas Springs will be individually packed in sealed clear plastic bags, to avoid damage, dust, or other foreign material - objects
 - 11 . Gas Spring to be assembled per the drawing with end fittings assembled / fastened
 - 12 . Gas Springs are not to be opened
 - 13 . Inside of each end fitting to be greased

NORMONT	DRAWN	NAME	DATE
	CHECKED	Faith	1/20/23
	DWG NO	NSM905A5E	REV 0
	TITLE Gas Spring		
THIS DOCUMENT AND ITS CONTENTS ARE THE PROPERTY OF NUJOMENG. THIS DOCUMENT CONTAINS CONFIDENTIAL PROPRIETARY INFORMATION. THE REPRODUCTION, DISTRIBUTION, UTILISATION OR THE COMMUNICATION OF THIS DOCUMENT OR ANY PART THEREOF, WITHOUT EXPRESS AUTHORISATION IS STRICTLY FORBIDDEN.	TOLERANCES		THIRD ANGLE PROJECTION
	X.X	± 0.060	
	X.XX	± 0.030	
	X.XXX	± 0.015	SCALE
ANGLES	± FE	N.T.S.	
HOLES	± 0.005	SIZE	
REMOVE ALL BURRS & BREAK ALL SHARP EDGES	ALL DIMENSIONS ARE IN inch UNLESS OTHERWISE SPECIFIED	SHEET 1 OF 1	B