

REVISION HISTORY			
REV	DESCRIPTION	DATE	APPROVED

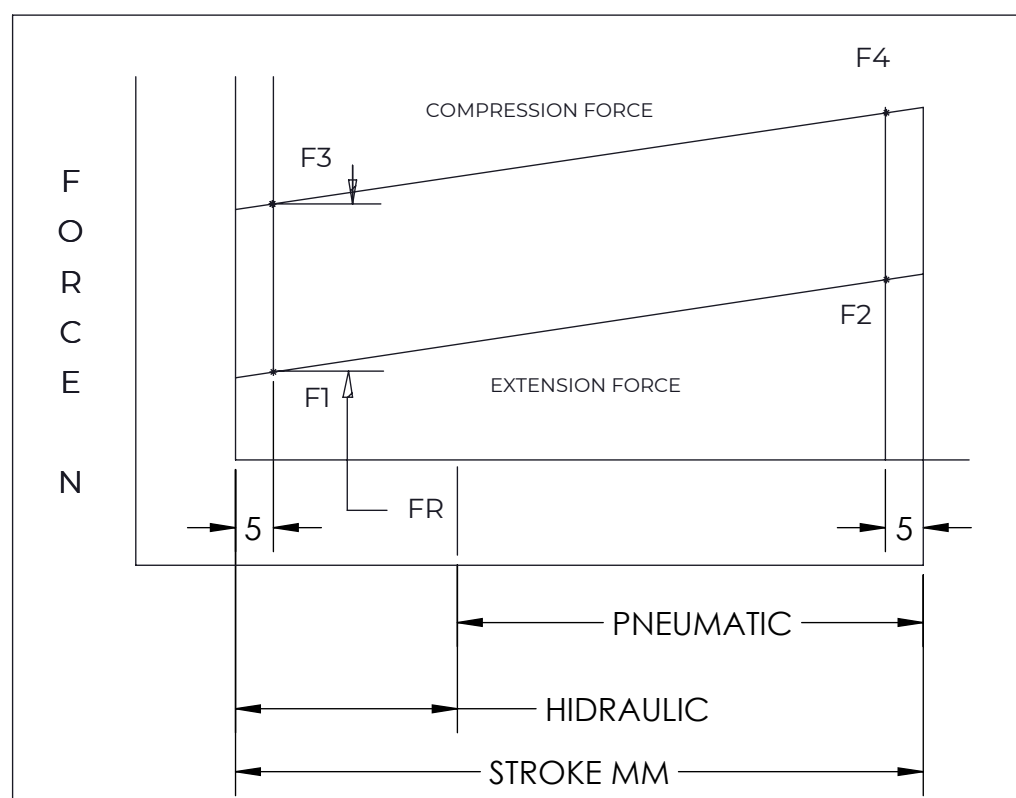
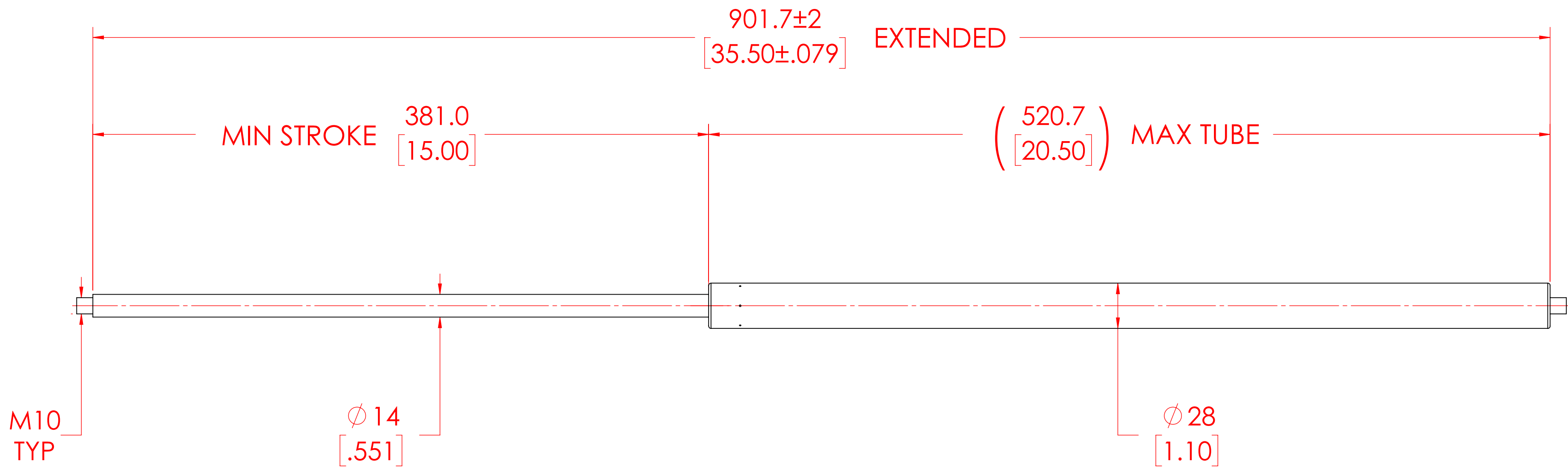

FORCES (STATICALLY MEASURED)	
F1	F2
300 LBS (1334 N) ^{+5%} / _{-5%}	-

NOTES:

- 1) MATERIAL: CYLINDER - STAINLESS STEEL 316, NO PAINT / ROD - STAINLESS STEEL 316.
- 2) OPERATING TEMPERATURE: -40°C TO +80°C.
- 3) STANDARD PART IDENTIFICATION TO INCLUDE PART NUMBER, DATE CODE AND WARNING MESSAGE.
- 4) GAS SPRING IS SUGGESTED TO BE MOUNTED SHAFT DOWN (ROD DOWN) FOR MAXIMUM PERFORMANCE.
- 5) GAS SPRINGS WILL BE SEALED IN CLEAR PLASTIC BAGS TO AVOID DAMAGE, DUST, OR OTHER FOREIGN OBJECTS.
- 6) GAS SPRING TO BE ASSEMBLED WITH END FITTINGS COMPLETELY FASTENED.

NORMONT		NAME	DATE
		DMA	05/06/2024
THIS DOCUMENT AND ITS CONTENTS ARE THE PROPERTY OF NORMONT THIS DOCUMENT CONTAINS CONFIDENTIAL PROPRIETARY INFORMATION. THE REPRODUCTION, DISTRIBUTION, UTILISATION OR THE COMMUNICATION OF THIS DOCUMENT OR ANY PART THEREOF, WITHOUT EXPRESS AUTHORISATION IS STRICTLY FORBIDDEN.		CHECKED	REV
		PART No.	NSSG3550X300
REMOVE ALL BURRS AND BREAK ALL SHARP EDGES		TITLE	SCALE
		STAINLESS STEEL GAS SPRING	NTS
ALL DIMENSIONS ARE DUAL UNLESS OTHERWISE SPECIFIED		TOLERANCES	THIRD ANGLE PROJECTION
		XX ± 0.060	
X.XX ± 0.030	SIZE		
X.XXX ± 0.010		C	
ANGLES ± 1°	SHEET 1 OF 1		
HOLES ± 0.005			