

REVISION HISTORY			
REV	DESCRIPTION	DATE	APPROVED

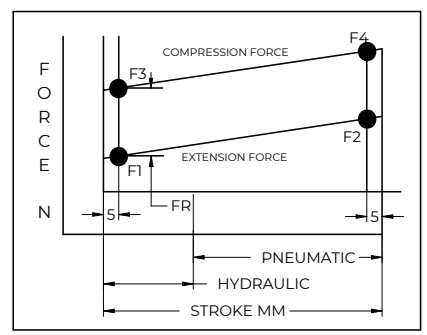
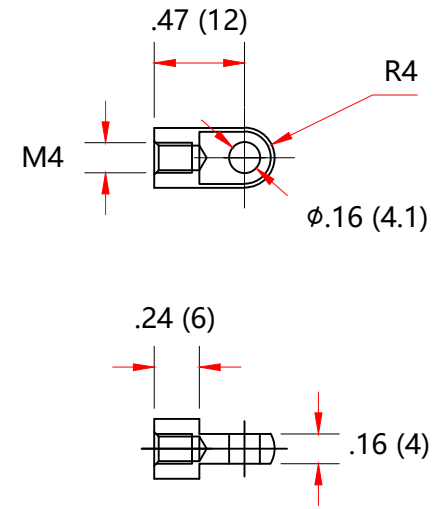
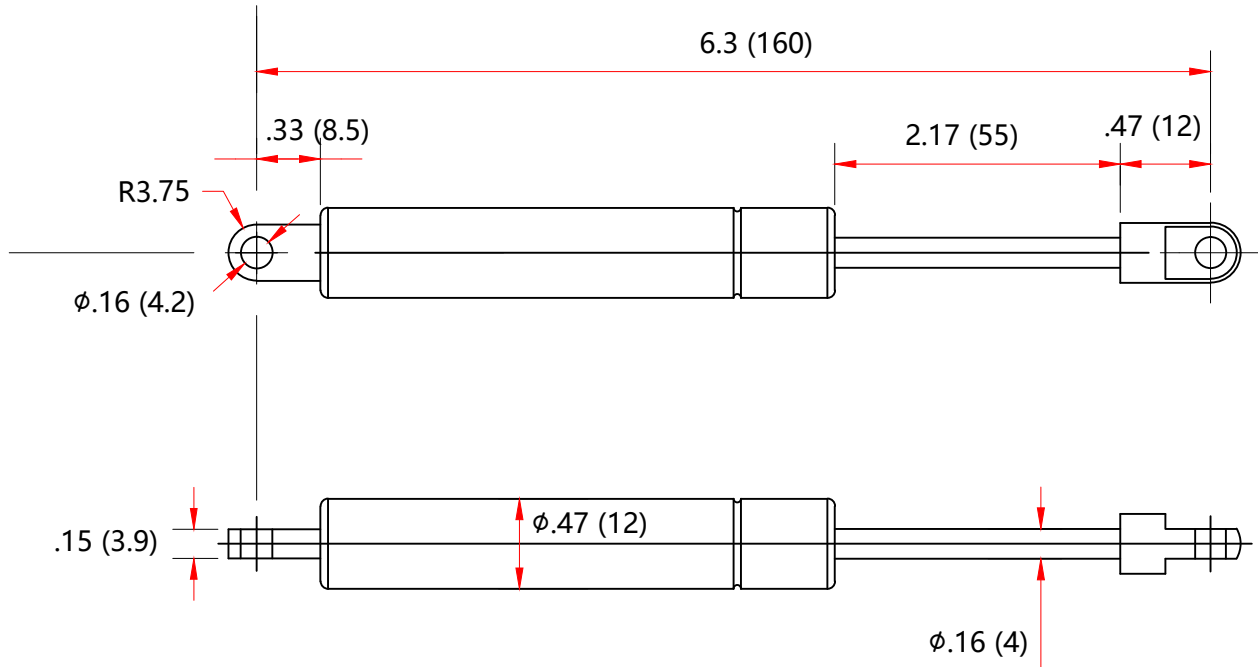

FORCES (STATICALLY MEASURED)	
F1	(F2)
25 LBS (111 N) +10%	-5%

- NOTES:**
- 1) MATERIAL: CYLINDER - STAINLESS STEEL 316. ROD - STAINLESS STEEL 316.
  - 2) DIMENSIONS ASSUMING END CONNECTORS ARE FULLY SCREWED INTO PLACE.
  - 3) DRAWING LENGTHS (NOT DIMENSIONED) OF CYLINDER AND ROD BODIES ARE NOT TO SCALE.
  - 4) OPERATING TEMPERATURE: -30°C TO +80°C.
  - 5) STANDARD LABEL TO INCLUDE PART NUMBER, DATE CODE AND WARNING MESSAGE. LABEL NOT TO BE REMOVED.
  - 6) GAS SPRING NOT TO BE CHANGED OR MODIFIED FROM ITS ORIGINAL MANUFACTURED INTENT.
  - 7) GAS SPRING IS SUGGESTED TO BE MOUNTED SHAFT DOWN (ROD DOWN) FOR MAXIMUM PERFORMANCE.
  - 8) CONNECTORS TO BE ORIENTED AS SHOWN ±5°.
  - 9) GAS SPRINGS WILL BE SEALED IN CLEAR PLASTIC BAGS TO AVOID DAMAGE, DUST, OR OTHER FOREIGN OBJECTS.
  - 10) GAS SPRINGS TO BE ASSEMBLED WITH END FITINGS COMPLETELY FASTENED.
  - 11) GAS SPRINGS ARE NOT TO BE OPENED.

<b>NORMONT</b>	DRAWN	NAME	DATE
	CHECKED	CSH	06/29/2023
	DWG NO	NSSM630A25E	REV 0
	TITLE <b>Gas Spring</b>		
THIS DOCUMENT AND ITS CONTENTS ARE THE PROPERTY OF NUJOMENG. THIS DOCUMENT CONTAINS CONFIDENTIAL PROPRIETARY INFORMATION. THE REPRODUCTION, DISTRIBUTION, UTILISATION OR THE COMMUNICATION OF THIS DOCUMENT OR ANY PART THEREOF, WITHOUT EXPRESS AUTHORISATION IS STRICTLY FORBIDDEN.	TOLERANCES		THIRD ANGLE PROJECTION
	X.X	±0.060	
	X.XX	±0.030	
	X.XXX	±0.015	SCALE N.T.S.
REMOVE ALL BURRS & BREAK ALL SHARP EDGES	ALL DIMENSIONS ARE IN <b>inch</b> UNLESS OTHERWISE SPECIFIED		
		ANGLES ±1.0°	SIZE <b>B</b>
		HOLES ±0.005	SHEET 1 OF 1