

REVISION HISTORY			
REV	DESCRIPTION	DATE	APPROVED
1			
2			
3			

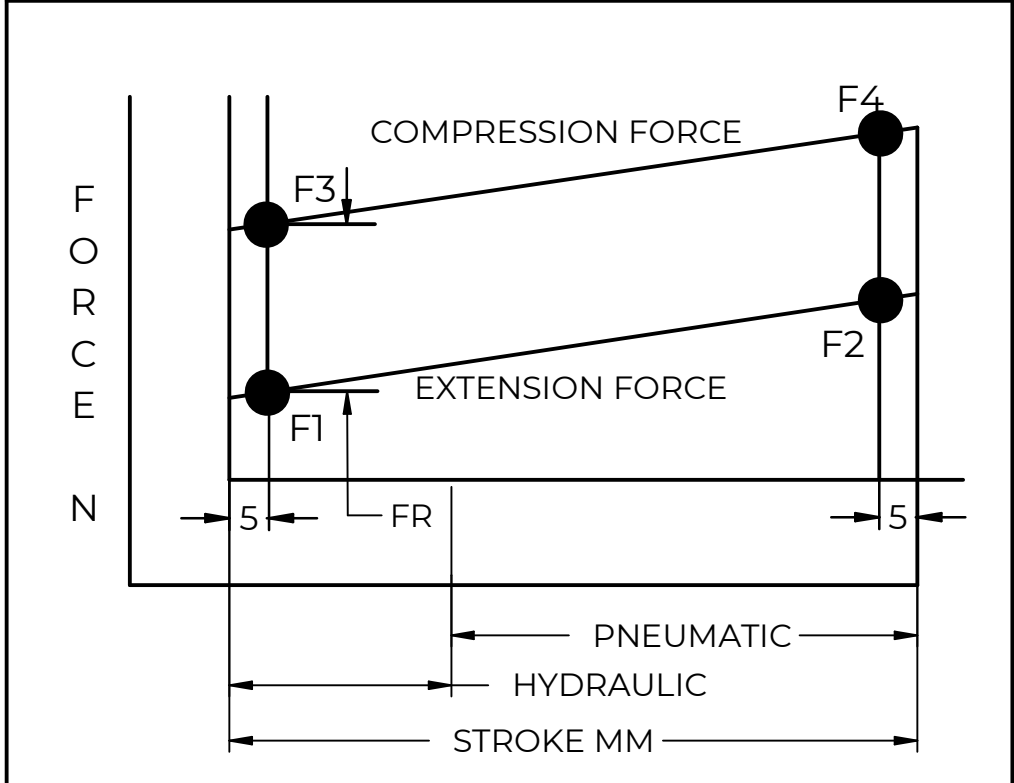
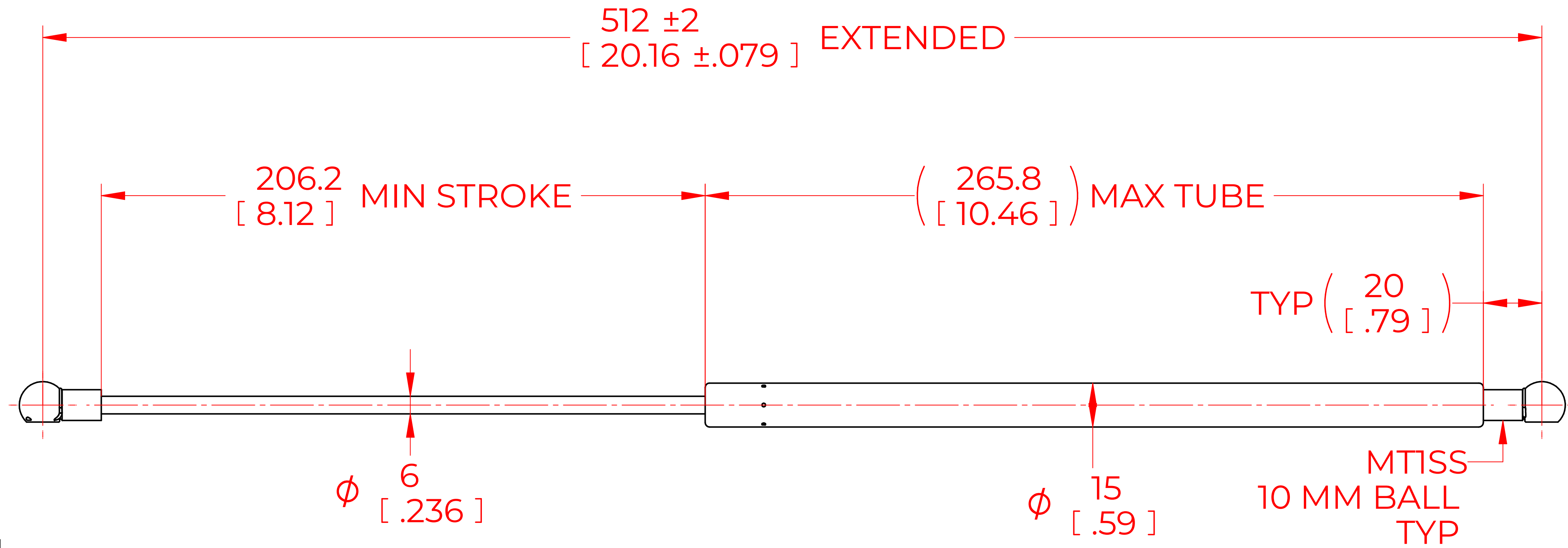

FORCES (STATICALLY MEASURED)	
F1	(F2)
40 LBS (178 N) +10% -5%	

- NOTES:
- 1) MATERIAL: CYLINDER - STAINLESS STEEL 316, NO PAINT / ROD - STAINLESS STEEL 316.
 - 2) OPERATING TEMPERATURE: -40°C TO +80°C.
 - 3) STANDARD PART IDENTIFICATION TO INCLUDE PART NUMBER, DATE CODE AND WARNING MESSAGE. WARNING MESSAGE.
 - 4) GAS SPRING IS SUGGESTED TO BE MOUNTED SHAFT DOWN (ROD DOWN) FOR MAXIMUM PERFORMANCE.
 - 5) END FITTINGS TO BE ORIENTED AS SHOWN ±5°.
 - 6) GAS SPRINGS WILL BE SEALED IN CLEAR PLASTIC BAGS TO AVOID DAMAGE, DUST, OR OTHER FOREIGN OBJECTS.
 - 7) GAS SPRING TO BE ASSEMBLED WITH END FITTINGS COMPLETELY FASTENED.
 - 8) GREASE TO BE INCLUDED INSIDE THE BALL SOCKET OF THE END FITTINGS.

NORMONT	NAME	DATE	
	DRAWN	DMA	05/02/2024
THIS DOCUMENT AND ITS CONTENTS ARE THE PROPERTY OF NORMONT THIS DOCUMENT CONTAINS CONFIDENTIAL PROPRIETARY INFORMATION. THE REPRODUCTION, DISTRIBUTION, UTILISATION OR THE COMMUNICATION OF THIS DOCUMENT OR ANY PART THEREOF, WITHOUT EXPRESS AUTHORISATION IS STRICTLY FORBIDDEN.	CHECKED		
	PART No.	REV	
	NSSG2000S40MTISS		
TITLE	GAS SPRING		
REMOVE ALL BURRS AND BREAK ALL SHARP EDGES	TOLERANCES	SCALE	
	X.X	± 0.060	THIRD ANGLE PROJECTION
	X.XX	± 0.030	
	X.XXX	± 0.010	SIZE
	ANGLES	± 1°	
HOLES	± 0.005	SHEET 1 OF 1	
ALL DIMENSIONS ARE DUAL UNLESS OTHERWISE SPECIFIED		D	