

REVISION HISTORY			
REV	DESCRIPTION	DATE	APPROVED

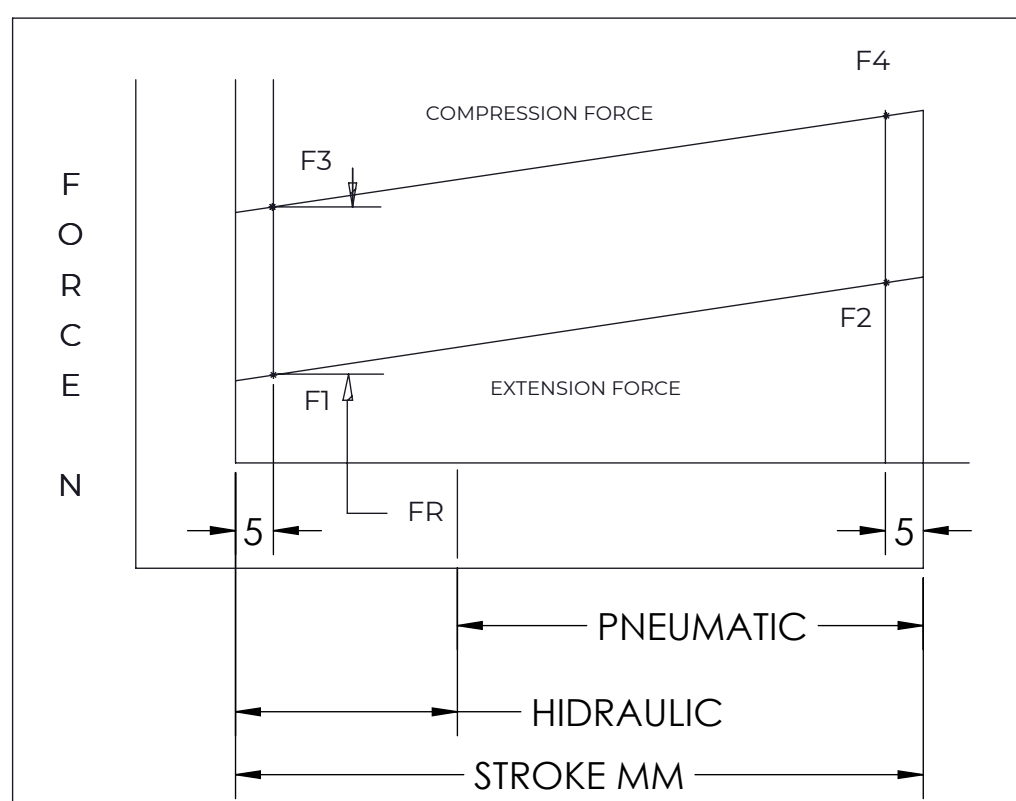
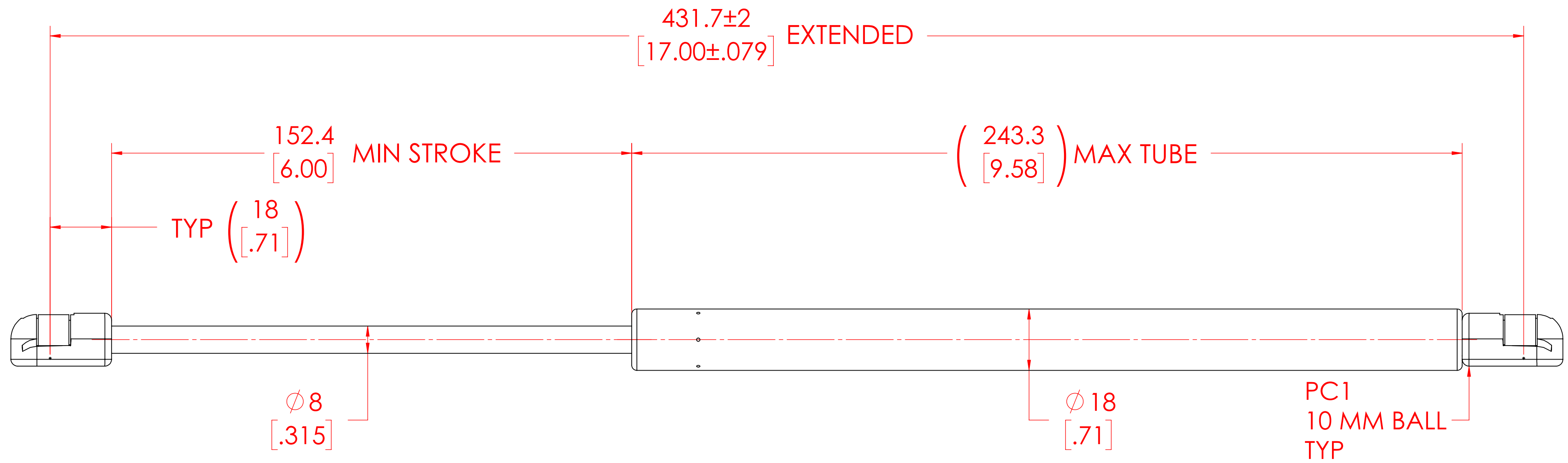

FORCES (STATICALLY MEASURED)	
F1	F2
40 LBS (178 N)	-
+25N -10N	-

- NOTES:**
- 1) MATERIAL: CYLINDER - STAINLESS STEEL 316, NO PAINT / ROD - STAINLESS STEEL 316.
  - 2) OPERATING TEMPERATURE: -40°C TO +80°C.
  - 3) STANDARD PART IDENTIFICATION TO INCLUDE PART NUMBER, DATE CODE AND WARNING MESSAGE.
  - 4) GAS SPRING IS SUGGESTED TO BE MOUNTED SHAFT DOWN (ROD DOWN) FOR MAXIMUM PERFORMANCE.
  - 5) END FITTINGS TO BE ORIENTED AS SHOWN ±5°.
  - 6) GAS SPRINGS WILL BE SEALED IN CLEAR PLASTIC BAGS TO AVOID DAMAGE, DUST, OR OTHER FOREIGN OBJECTS.
  - 7) GAS SPRING TO BE ASSEMBLED WITH END FITTINGS COMPLETELY FASTENED.
  - 8) GREASE TO BE INCLUDED INSIDE THE BALL SOCKET OF THE END FITTINGS.

<h1>NORMONT</h1> <p>THIS DOCUMENT AND ITS CONTENTS ARE THE PROPERTY OF NORMONT</p> <p>THIS DOCUMENT CONTAINS CONFIDENTIAL PROPRIETARY INFORMATION. THE REPRODUCTION, DISTRIBUTION, UTILISATION OR THE COMMUNICATION OF THIS DOCUMENT OR ANY PART THEREOF, WITHOUT EXPRESS AUTHORISATION IS STRICTLY FORBIDDEN.</p>	NAME	DATE	
	DRAWN	DMA	05/06/2024
	CHECKED		
	PART No.	NSSG1700M40PC1	REV
TITLE	STAINLESS STEEL GAS SPRING		
TOLERANCES	THIRD ANGLE PROJECTION 	SCALE	
XX		± 0.060	<b>NTS</b>
X.XX		± 0.030	
X.XXX		± 0.010	SIZE
ANGLES		± 1°	<b>C</b>
HOLES	± 0.005		
REMOVE ALL BURRS AND BREAK ALL SHARP EDGES	ALL DIMENSIONS ARE <b>DUAL</b> UNLESS OTHERWISE SPECIFIED	SHEET 1 OF 1	